

SERVICE & OPERATING MANUAL

Original Instructions

Certified Quality



Quality System
ISO9001 Certified



Environmental Management System
ISO14001 Certified



Warren Rupp, Inc.
A Unit of IDEX Corporation
800 N. Main St.,
Mansfield, Ohio 44902 USA
Telephone (419) 524.8388
Fax (419) 522.7867
WWW.SANDPIPERPUMP.COM



©2011 Warren Rupp, Inc.

Model S1F

Metallic
Design Level 1

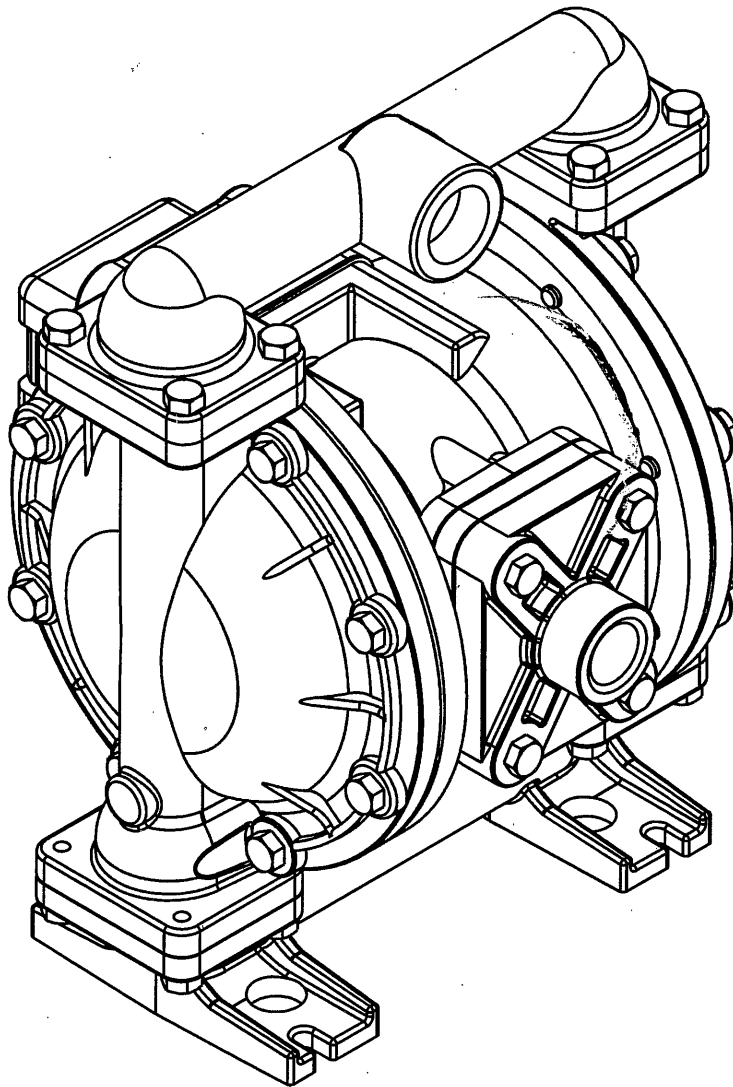

1: PUMP SPECS

2: INSTAL & OP

3: EXP VIEW

4: AIR END

5: WET END

6: OPTIONAL

7: WARRANTY

SANDPIPER®

A WARREN RUPP INC BRAND

WWW.SANDPIPERPUMP.COM

Safety Information

IMPORTANT



Read the safety warnings and instructions in this manual before pump installation and start-up. Failure to comply with the recommendations stated in this manual could damage the pump and void factory warranty.



When the pump is used for materials that tend to settle out or solidify, the pump should be flushed after each use to prevent damage. In freezing temperatures the pump should be completely drained between uses.

CAUTION



Before pump operation, inspect all fasteners for loosening caused by gasket creep. Retighten loose fasteners to prevent leakage. Follow recommended torques stated in this manual.



Nonmetallic pumps and plastic components are not UV stabilized. Ultraviolet radiation can damage these parts and negatively affect material properties. Do not expose to UV light for extended periods of time.

WARNING



When used for toxic or aggressive fluids, the pump should always be flushed clean prior to disassembly.



Before maintenance or repair, shut off the compressed air line, bleed the pressure, and disconnect the air line from the pump. Be certain that approved eye protection and protective clothing are worn at all times. Failure to follow these recommendations may result in serious injury or death.



Airborne particles and loud noise hazards. Wear eye and ear protection.



In the event of diaphragm rupture, pumped material may enter the air end of the pump, and be discharged into the atmosphere. If pumping a product that is hazardous or toxic, the air exhaust must be piped to an appropriate area for safe containment.



Take action to prevent static sparking. Fire or explosion can result, especially when handling flammable liquids. The pump, piping, valves, containers and other miscellaneous equipment must be properly grounded.



This pump is pressurized internally with air pressure during operation. Make certain that all fasteners are in good condition and are reinstalled properly during reassembly.

Grounding the Pump

To be fully groundable, the pumps must be ATEX Compliant. Refer to the nomenclature page for ordering information.

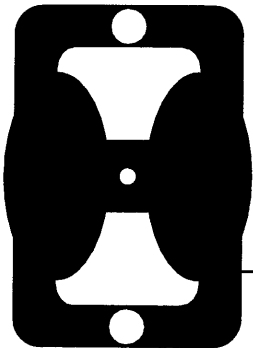

Optional 8 foot long (244 centimeters) Ground Strap is available for easy ground connection.

To reduce the risk of static electrical sparking, this pump must be grounded. Check the local electrical code for detailed grounding instruction and the type of equipment required.

Refer to nomenclature page for ordering information.

WARNING



Take action to prevent static sparking. Fire or explosion can result, especially when handling flammable liquids. The pump, piping, valves, containers or other miscellaneous equipment must be grounded.

Table of Contents

SECTION 1: PUMP SPECIFICATIONS.....1

- Explanation of Nomenclature
- Performance
- Materials
- Dimensional Drawings

SECTION 2: INSTALLATION & OPERATION.....4

- Principle of Pump Operation
- Recommended Installation Guide
- Troubleshooting Guide

SECTION 3: EXPLODED VIEW.....7

- Composite Repair Parts Drawing
- Composite Repair Parts List
- Material Codes

SECTION 4: AIR END.....10

- Air Distribution Valve Assembly
- Air Valve with Stroke Indicator Assembly
- Pilot Valve Assembly
- Intermediate Assembly

SECTION 5: WET END17

- Diaphragm Drawings
- Diaphragm Servicing

SECTION 6: OPTIONAL CONFIGURATIONS....19

- Solenoid Shifted Air Valve

SECTION 7: WARRANTY & CERTIFICATES20

- Warranty
- CE Declaration of Conformity - Machinery
- ATEX Declaration of Conformity
- ATEX Summary of Markings

1: PUMP SPECS

2: INSTAL & OP

3: EXP VIEW

4: AIR END

5: WET END

6: OPTIONAL

7: WARRANTY

Explanation of Pump Nomenclature

1: PUMP SPECS

Your Model #: **S** _____
 (1st in from pump nameplate)

Pump Brand	Pump Size	Check Valve	Design Level	Wetted Material	Diaphragm/Check Valve	Check Valve Seat	Non-Wetted Material	Porting Options	Pump Style	Muffler Options	Pump Options
------------	-----------	-------------	--------------	-----------------	-----------------------	------------------	---------------------	-----------------	------------	-----------------	--------------

Model #: **S XX X X X X X X X X X XX**

Pump Brand
S SANDPIPER®

Pump Size
1F 1"

Check Valve Type
B Ball

Design Level
1 Design Level

Wetted Material
A Aluminum
I Cast Iron
S Stainless Steel
H Alloy C

Diaphragm/Check Valve Materials
1 Santoprene/Santoprene
B Nitrile/Nitrile
C FKM/PTFE
I EPDM/Santoprene
G PTFE-Neoprene/PTFE
N Neoprene/Neoprene
Z One-Piece Bonded/PTFE

Check Valve Seat
A Aluminum
C Carbon Steel
S Stainless Steel
T PTFE
W UHMW

Non-Wetted Material Options

- A Painted Aluminum
- I Cast Iron
- Y Painted Aluminum with Stainless Steel Hardware
- Z Cast Iron with Stainless Steel Hardware

Porting Options

- N NPT Threads
- B BSP (Tapered) Threads
- R Raised Face 150# Threaded ANSI Flange

Pump Style

- S Standard

Muffler Options

- 0 None
- 1 Sound Dampening Muffler
- 2 Mesh Muffler
- 3 High temperature Air Valve w/Encapsulated Muffler
- 4 High temperature Air Valve w/Sound Dampening Muffler
- 5 High temperature Air Valve w/Mesh Muffler
- ▲ 6 Metal Muffler
- ▲ 7 Metal Muffler with Grounding Cable

Pump Options

- ▲ 00. None
- P0. 10.30VDC Pulse Output Kit
- ◆ P1. Intrinsically-Safe 5.30VDC, 110/120VAC 220/240 VAC Pulse Output Kit
- P2. 110/120 or 220/240VAC Pulse Output Kit
- E0. Solenoid Kit with 24VDC Coil
- ▲ E1. Solenoid Kit with 24VDC Explosion-Proof Coil
- E2. Solenoid Kit with 24VAC/12VDC Coil
- ▲ E3. Solenoid Kit with 12VDC Explosion-Proof Coil
- E4. Solenoid Kit with 110VAC Coil
- ▲ E5. Solenoid Kit with 110VAC Explosion-Proof Coil
- E6. Solenoid Kit with 220VAC Coil
- ▲ E7. Solenoid Kit with 220VAC Explosion-Proof Coil
- ▲ E8. Solenoid Kit with 110VAC, 50 Hz Explosion-Proof Coil
- ▲ E9. Solenoid Kit with 230VAC, 50 Hz Explosion-Proof Coil
- SP. Stroke Indicator Pins
- ◆ A1. Solenoid Kit with 12 VDC ATEX Compliant Coil
- ◆ A2. Solenoid Kit with 24 VDC ATEX Compliant Coil
- ◆ A3. Solenoid Kit with 110/120 VAC 50/60 Hz ATEX Compliant Coil
- ◆ A4. Solenoid Kit with 220/240 VAC 50/60 Hz ATEX Compliant Coil

Your Serial #: (1st in from pump nameplate) _____

ATEX Detail

(1)  II 1G c T5
 II 3/1 G c T5
 II 1D c T100°C
 ▲ I M1 c
 I M2 c
 Models equipped with Wetted Options I, S or H, Non-Wetted Options I or Z Pump Options 6 or 7, and Kit Option 0.
Note: See ATEX Explanation of EC-Type Certificate

II 2G c T5
 II 3/2 G c T5
 II 2D c T100°C
 Models equipped with Wetted Options A, I, S, or H, Non-Wetted Options A, I, Y, or Z, Pump Options 6 or 7, and Kit Option 0.
Note: See page 19 for ATEX Explanation of Type Examination Certificate

(2)  II 2G Ex ia c IIC T5
 II 3/2 G Ex ia c IIC T5
 II 2D Ex c ia 20 IP67 T100°C

◆ **Note:** Pumps ordered with the options listed in (1) to the left are ATEX compliant when ordered with kit option P1.

(3)  II 2G EEEx m c II T5
 II 3/2 2G EEEx m c II T5
 II 2D c IP65 T100°C

◆ **Note:** Pumps ordered with the options listed in (1) to the left are ATEX compliant when ordered with kit option A1, A2, A3, or A4. Compressed Air Temperature Range: Maximum Ambient Temperature to plus 50°C.
 *Note: See page 16 for Special Conditions For Safe Use.

(4)  IEC EEx m T4



▲ **Note:** Pump models equipped with these explosion-proof solenoid kit options E1, E3, E5, E7, E8 or E9, are certified and approved by the above agencies. They are NOT ATEX compliant.

Special condition for safe use:
 Conductive polypropylene, conductive acetal, or conductive PVDF pumps are not to be installed in applications where the pumps may be subjected to oil, greases and hydraulic liquids.

Performance

S1F METALLIC

SUCTION/DISCHARGE PORT SIZE

- 1" NPT (internal)
- 1" BSP Tapered (internal)

CAPACITY

- 0 to 45 gallons per minute (0 to 170 liters per minute)

AIR DISTRIBUTION VALVE

- No-lube, no-stall design

SOLIDS-HANDLING

- Up to .25 in. (6mm)

HEADS UP TO

- 125 psi or 289 ft. of water (8.6 Kg/cm² or 86 meters)

DISPLACEMENT/STROKE

- .011 Gallon / .042 liter

MAXIMUM OPERATING PRESSURE

- 125 psi (8.6 bar)

SHIPPING WEIGHT

- Aluminum 28 lbs. (13kg)
- Cast Iron 46 lbs. (21kg)
- Stainless Steel 43 lbs. (20kg)

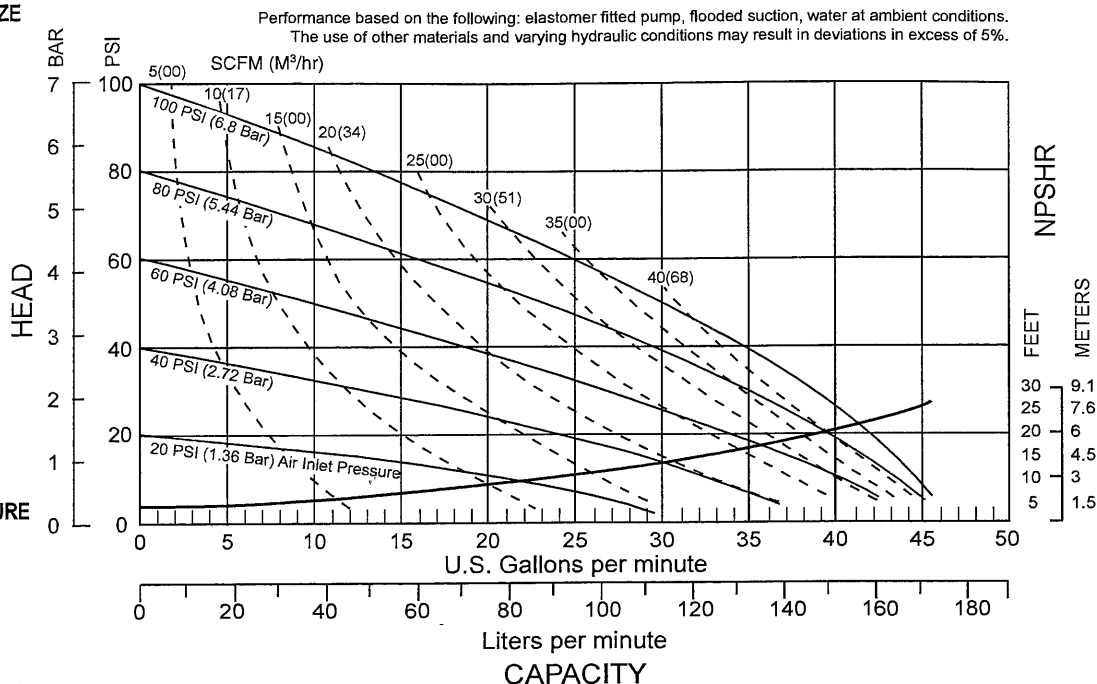

1: PUMP SPECS

Materials

Material Profile:	Operating Temperatures:	
	Max.	Min.
CAUTION! Operating temperature limitations are as follows: Conductive Acetal: Tough, impact resistant, ductile. Good abrasion resistance and low friction surface. Generally inert, with good chemical resistance except for strong acids and oxidizing agents.	190°F 88°C	-20°F -29°C
EPDM: Shows very good water and chemical resistance. Has poor resistance to oils and solvents, but is fair in ketones and alcohols.	280°F 138°C	-40°F -40°C
FKM: (Fluorocarbon) Shows good resistance to a wide range of oils and solvents; especially all aliphatic, aromatic and halogenated hydrocarbons, acids, animal and vegetable oils. Hot water or hot aqueous solutions (over 70°F(21°C)) will attack FKM.	350°F 177°C	-40°F -40°C
Hytre®: Good on acids, bases, amines and glycols at room temperatures only.	220°F 104°C	-20°F -29°C
Neoprene: All purpose. Resistance to vegetable oils. Generally not affected by moderate chemicals, fats, greases and many oils and solvents. Generally attacked by strong oxidizing acids, ketones, esters and nitro hydrocarbons and chlorinated aromatic hydrocarbons.	200°F 93°C	-10°F -23°C
Nitrile: General purpose, oil-resistant. Shows good solvent, oil, water and hydraulic fluid resistance. Should not be used with highly polar solvents like acetone and MEK, ozone, chlorinated hydrocarbons and nitro hydrocarbons.	190°F 88°C	-10°F -23°C
Nylon: 6/6 High strength and toughness over a wide temperature range. Moderate to good resistance to fuels, oils and chemicals.	180°F 82°C	32°F 0°C

Ambient temperature range: -20°C to +40°C
 Process temperature range: -20°C to +80°C for models rated as category 1 equipment
 -20°C to +100°C for models rated as category 2 equipment

In addition, the ambient temperature range and the process temperature range do not exceed the operating temperature range of the applied non-metallic parts as listed in the manuals of the pumps.

Polypropylene: A thermoplastic polymer. Moderate tensile and flex strength. Resists strong acids and alkali. Attacked by chlorine, fuming nitric acid and other strong oxidizing agents.	180°F 82°C	32°F 0°C
PVDF: (Polyvinylidene Fluoride) A durable fluoroplastic with excellent chemical resistance. Excellent for UV applications. High tensile strength and impact resistance.	250°F 121°C	0°F -18°C
Santoprene®: Injection molded thermoplastic elastomer with no fabric layer. Long mechanical flex life. Excellent abrasion resistance.	275°F 135°C	-40°F -40°C
UHMW PE: A thermoplastic that is highly resistant to a broad range of chemicals. Exhibits outstanding abrasion and impact resistance, along with environmental stress-cracking resistance.	180°F 82°C	-35°F -37°C
Urethane: Shows good resistance to abrasives. Has poor resistance to most solvents and oils.	150°F 66°C	32°F 0°C
Virgin PTFE: (PFA/TFE) Chemically inert, virtually impervious. Very few chemicals are known to chemically react with PTFE; molten alkali metals, turbulent liquid or gaseous fluorine and a few fluoro-chemicals such as chlorine trifluoride or oxygen difluoride which readily liberate free fluorine at elevated temperatures.	220°F 104°C	-35°F -37°C
<i>Maximum and Minimum Temperatures are the limits for which these materials can be operated. Temperatures coupled with pressure affect the longevity of diaphragm pump components. Maximum life should not be expected at the extreme limits of the temperature ranges.</i>		
Metals:		
Alloy C: Equal to ASTM494 CW-12M-1 specification for nickel and nickel alloy.		
Stainless Steel: Equal to or exceeding ASTM specification A743 CF-8M for corrosion resistant iron chromium, iron chromium nickel and nickel based alloy castings for general applications. Commonly referred to as 316 Stainless Steel in the pump industry.		

For specific applications, always consult the Chemical Resistance Chart.

Dimensional Drawings

S1F Metallic

Dimensions in Inches. Dimensional Tolerance: $\pm 1/8"$

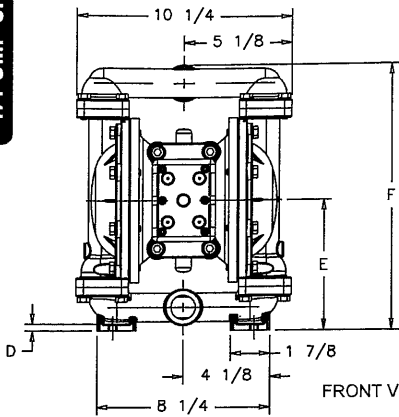

FRONT VIEW

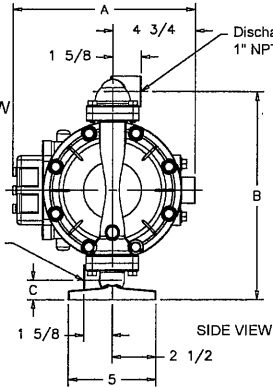

SIDE VIEW

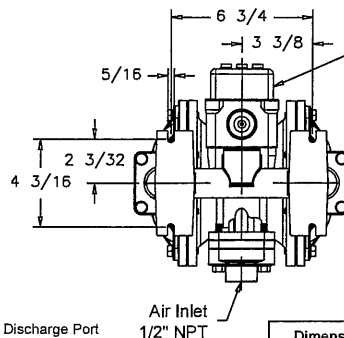

Integral Muffler
1" NPT Exhaust Port
For Optional Muffler
Styles Or Piping Exhaust
Air In Submerged
Applications.

BOTTOM VIEW

Dimension	A	B	C	D	E	F
Encapsulated Muffler	10 3/8					
Pulse Output Kit	10 3/8					
Aluminum		11 27/32	1 3/32	5/16	6 7/32	12 23/32
Stainless Steel		11 31/32	1 7/32	7/16	6 11/32	12 27/32
Mesh Muffler	13					
Sound Dampening Muffler	13					
Metal Muffler	12 1/2					

Pump Shown
With 530-028-550
Integral Muffler

Both Suction And
Discharge Ports Are
Available With
1" BSP Tapered Connection

S1F Metallic

Dimensions in Millimeters. Dimensional Tolerance: $\pm 3\text{mm}$

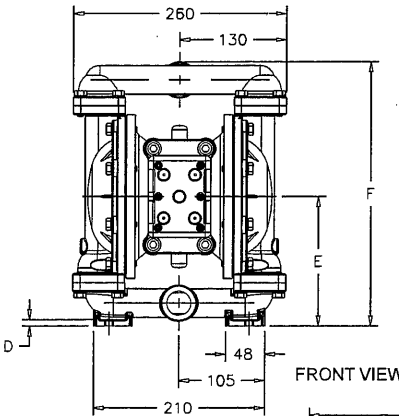

FRONT VIEW

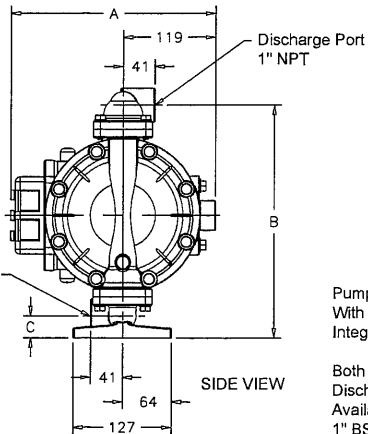

SIDE VIEW

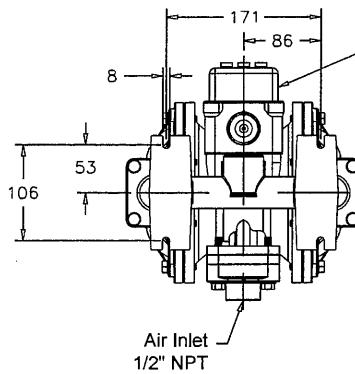

Integral Muffler
1" NPT Exhaust Port
For Optional Muffler
Styles Or Piping Exhaust
Air In Submerged
Applications

BOTTOM VIEW

Dimension	A	B	C	D	E	F
Encapsulated Muffler	264					
Pulse Output Kit	264					
Aluminum		301	28	8	158	323
Stainless Steel		304	31	11	161	326
Mesh Muffler	330					
Sound Dampening Muffler	330					
Metal Muffler	319					

Pump Shown
With 530-028-550
Integral Muffler

Both Suction And
Discharge Ports Are
Available With
1" BSP Tapered Connection

Principle of Pump Operation

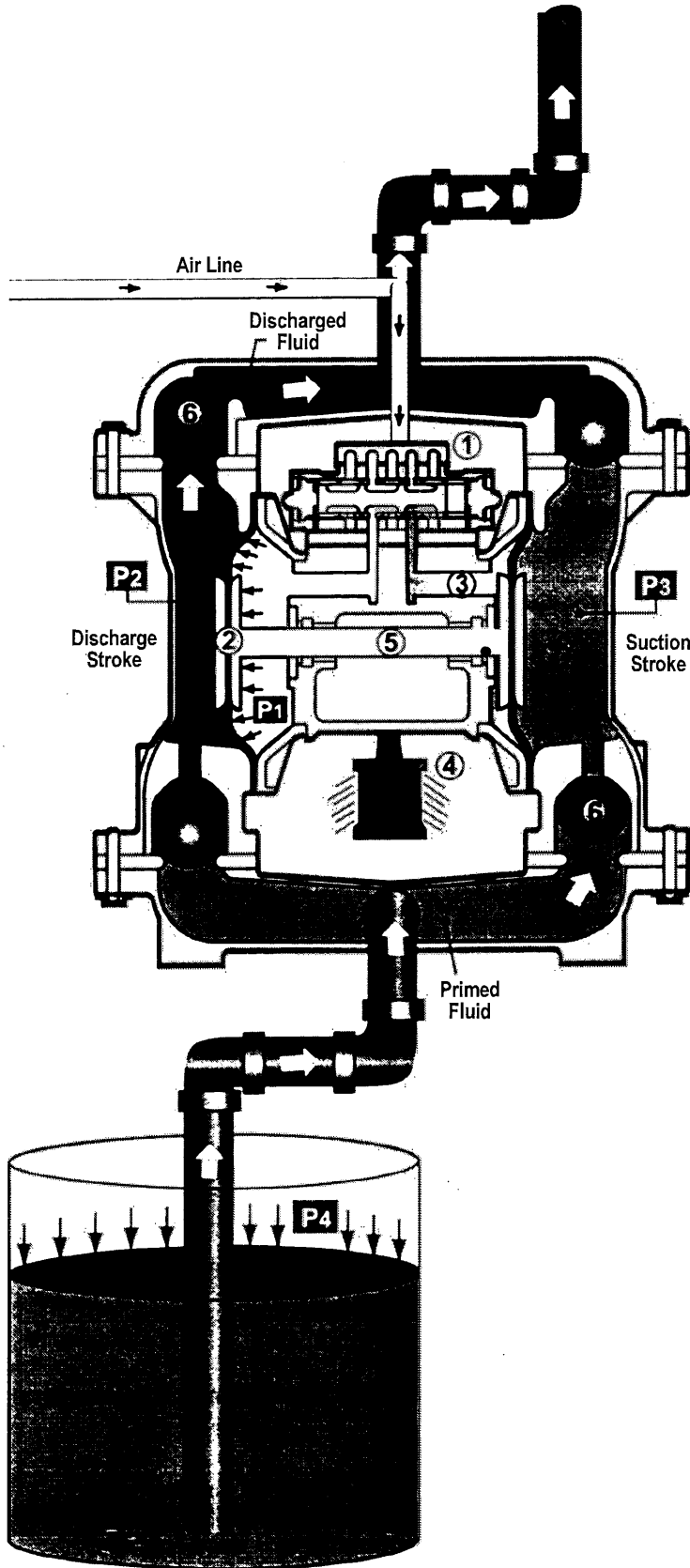

Air-Operated Double Diaphragm (AODD) pumps are powered by compressed air, nitrogen or natural gas.

The main directional (air) control valve ① distributes compressed air to an air chamber, exerting uniform pressure over the inner surface of the diaphragm ②. At the same time, the exhausting air ③ from behind the opposite diaphragm is directed through the air valve assembly(s) to an exhaust port ④.

As inner chamber pressure (P1) exceeds liquid chamber pressure (P2), the rod ⑤ connected diaphragms shift together creating discharge on one side and suction on the opposite side. The discharged and primed liquid's directions are controlled by the check valves (ball or flap) ⑥ orientation.

The pump primes as a result of the suction stroke. The suction stroke lowers the chamber pressure (P3) increasing the chamber volume. This results in a pressure differential necessary for atmospheric pressure (P4) to push the fluid through the suction piping and across the suction side check valve and into the outer fluid chamber ⑦.

Suction (side) stroking also initiates the reciprocating (shifting, stroking or cycling) action of the pump. The suction diaphragm's movement is mechanically pulled through its stroke. The diaphragm's inner plate makes contact with an actuator plunger aligned to shift the pilot signaling valve. Once actuated, the pilot valve sends a pressure signal to the opposite end of the main directional air valve, redirecting the compressed air to the opposite inner chamber.

SUBMERGED ILLUSTRATION

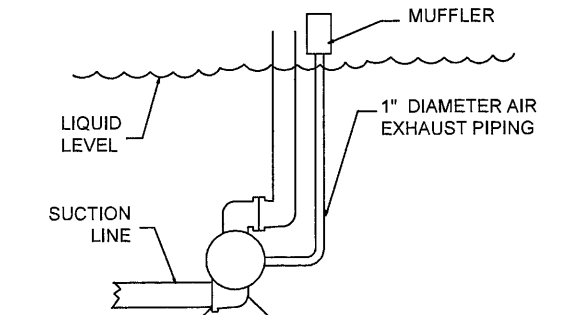

Pump can be submerged if the pump materials of construction are compatible with the liquid being pumped. The air exhaust must be piped above the liquid level. When the pumped product source is at a higher level than the pump (flooded suction condition), pipe the exhaust higher than the product source to prevent siphoning spills.

2: INSTAL & OP

Recommended Installation Guide

Available Accessories:

1. Surge Suppressor
2. Filter/Regulator
3. Air Dryer

Note: Surge Suppressor and Piping must be supported after the flexible connection

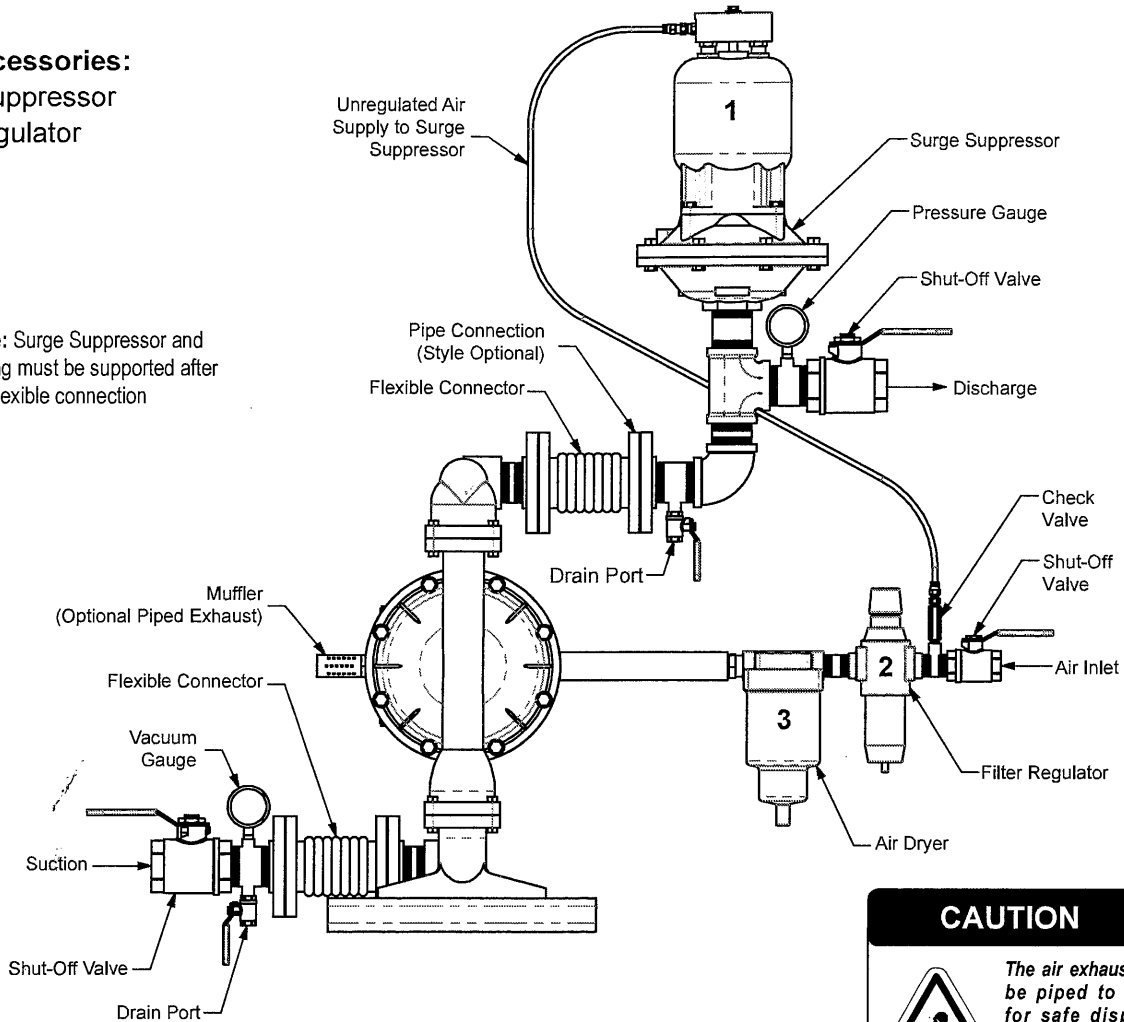

CAUTION



The air exhaust should be piped to an area for safe disposition of the product being pumped, in the event of a diaphragm failure.

Installation And Start-Up

Locate the pump as close to the product being pumped as possible. Keep the suction line length and number of fittings to a minimum. Do not reduce the suction line diameter.

Air Supply

Connect the pump air inlet to an air supply with sufficient capacity and pressure to achieve desired performance. A pressure regulating valve should be installed to insure air supply pressure does not exceed recommended limits.

Air Valve Lubrication

The air distribution system is designed to operate WITHOUT lubrication. This is the standard mode of operation. If lubrication is desired, install an air line lubricator set to deliver one drop of SAE 10 non-detergent oil for every 20 SCFM (9.4 liters/sec.) of air the pump consumes. Consult the Performance Curve to determine air consumption.

Air Line Moisture

Water in the compressed air supply may cause icing or freezing of the exhaust air, causing the pump to cycle erratically or stop operating. Water in the air supply can be reduced by using a point-of-use air dryer.

Air Inlet And Priming

To start the pump, slightly open the air shut-off valve. After the pump primes, the air valve can be opened to increase air flow as desired. If opening the valve increases cycling rate, but does not increase the rate of flow, cavitation has occurred. The valve should be closed slightly to obtain the most efficient air flow to pump flow ratio.

Troubleshooting Guide

Symptom:	Potential Cause(s):	Recommendation(s):
Pump Cycles Once	Deadhead (system pressure meets or exceeds air supply pressure).	Increase the inlet air pressure to the pump. Pump is designed for 1:1 pressure ratio at zero flow. (Does not apply to high pressure 2:1 units).
	Air valve or intermediate gaskets installed incorrectly.	Install gaskets with holes properly aligned.
	Bent or missing actuator plunger.	Remove pilot valve and inspect actuator plungers.
Pump Will Not Operate / Cycle	Pump is over lubricated.	Set lubricator on lowest possible setting or remove. Units are designed for lube free operation.
	Lack of air (line size, PSI, CFM).	Check the air line size and length, compressor capacity (HP vs. CFM required).
	Check air distribution system.	Disassemble and inspect main air distribution valve, pilot valve and pilot valve actuators.
	Discharge line is blocked or clogged manifolds.	Check for inadvertently closed discharge line valves. Clean discharge manifolds/piping.
	Deadhead (system pressure meets or exceeds air supply pressure).	Increase the inlet air pressure to the pump. Pump is designed for 1:1 pressure ratio at zero flow. (Does not apply to high pressure 2:1 units).
	Blocked air exhaust muffler.	Remove muffler screen, clean or de-ice, and re-install.
	Pumped fluid in air exhaust muffler.	Disassemble pump chambers. Inspect for diaphragm rupture or loose diaphragm plate assembly.
Pump chamber is blocked.	Disassemble and inspect wetted chambers. Remove or flush any obstructions.	
Pump Cycles and Will Not Prime or No Flow	Cavitation on suction side.	Check suction condition (move pump closer to product).
	Check valve obstructed. Valve ball(s) not seating properly or sticking.	Disassemble the wet end of the pump and manually dislodge obstruction in the check valve pocket. Clean out around valve ball cage and valve seat area. Replace valve ball or valve seat if damaged. Use heavier valve ball material.
	Valve ball(s) missing (pushed into chamber or manifold).	Worn valve ball or valve seat. Worn fingers in valve ball cage (replace part). Check Chemical Resistance Guide for compatibility.
	Valve ball(s) / seat(s) damaged or attacked by product.	Check Chemical Resistance Guide for compatibility.
	Check valve and/or seat is worn or needs adjusting.	Inspect check valves and seats for wear and proper setting. Replace if necessary.
	Suction line is blocked.	Remove or flush obstruction. Check and clear all suction screens or strainers.
	Excessive suction lift.	For lifts exceeding 20' of liquid, filling the chambers with liquid will prime the pump in most cases.
	Suction side air leakage or air in product.	Visually inspect all suction-side gaskets and pipe connections.
	Pumped fluid in air exhaust muffler.	Disassemble pump chambers. Inspect for diaphragm rupture or loose diaphragm plate assembly.
Pump Cycles Running Sluggish / Stalling, Flow Unsatisfactory	Over lubrication.	Set lubricator on lowest possible setting or remove. Units are designed for lube free operation.
	Icing.	Remove muffler screen, de-ice, and re-install. Install a point of use air drier.
	Clogged manifolds.	Clean manifolds to allow proper air flow.
	Deadhead (system pressure meets or exceeds air supply pressure).	Increase the inlet air pressure to the pump. Pump is designed for 1:1 pressure ratio at zero flow. (Does not apply to high pressure 2:1 units).
	Cavitation on suction side.	Check suction (move pump closer to product).
	Lack of air (line size, PSI, CFM).	Check the air line size, length, compressor capacity.
	Excessive suction lift.	For lifts exceeding 20' of liquid, filling the chambers with liquid will prime the pump in most cases.
	Air supply pressure or volume exceeds system hd.	Decrease inlet air (press. and vol.) to the pump. Pump is cavitating the fluid by fast cycling.
	Undersized suction line.	Meet or exceed pump connections.
	Restrictive or undersized air line.	Install a larger air line and connection.
	Suction side air leakage or air in product.	Visually inspect all suction-side gaskets and pipe connections.
	Suction line is blocked.	Remove or flush obstruction. Check and clear all suction screens or strainers.
	Pumped fluid in air exhaust muffler.	Disassemble pump chambers. Inspect for diaphragm rupture or loose diaphragm plate assembly.
	Check valve obstructed.	Disassemble the wet end of the pump and manually dislodge obstruction in the check valve pocket.
Check valve and/or seat is worn or needs adjusting.	Inspect check valves and seats for wear and proper setting. Replace if necessary.	
Entrained air or vapor lock in chamber(s).	Purge chambers through tapped chamber vent plugs. Purging the chambers of air can be dangerous.	
Product Leaking Through Exhaust	Diaphragm failure, or diaphragm plates loose.	Replace diaphragms, check for damage and ensure diaphragm plates are tight.
	Diaphragm stretched around center hole or bolt holes.	Check for excessive inlet pressure or air pressure. Consult Chemical Resistance Chart for compatibility with products, cleaners, temperature limitations and lubrication.
Premature Diaphragm Failure	Cavitation.	Enlarge pipe diameter on suction side of pump.
	Excessive flooded suction pressure.	Move pump closer to product. Raise pump/place pump on top of tank to reduce inlet pressure. Install Back pressure device (Tech bulletin 41r). Add accumulation tank or pulsation dampener.
	Misapplication (chemical/physical incompatibility).	Consult Chemical Resistance Chart for compatibility with products, cleaners, temperature limitations and lubrication.
	Incorrect diaphragm plates or plates on backwards, installed incorrectly or worn.	Check Operating Manual to check for correct part and installation. Ensure outer plates have not been worn to a sharp edge.
Unbalanced Cycling	Excessive suction lift.	For lifts exceeding 20' of liquid, filling the chambers with liquid will prime the pump in most cases.
	Undersized suction line.	Meet or exceed pump connections.
	Pumped fluid in air exhaust muffler.	Disassemble pump chambers. Inspect for diaphragm rupture or loose diaphragm plate assembly.
	Suction side air leakage or air in product.	Visually inspect all suction-side gaskets and pipe connections.
	Check valve obstructed.	Disassemble the wet end of the pump and manually dislodge obstruction in the check valve pocket.
	Check valve and/or seat is worn or needs adjusting.	Inspect check valves and seats for wear and proper setting. Replace if necessary.
	Entrained air or vapor lock in chamber(s).	Purge chambers through tapped chamber vent plugs.

2: INSTAL & OP

For additional troubleshooting tips contact After Sales Support at service.warrenrupp@idexcorp.com or 419-524-8388



Composite Repair Parts Drawing

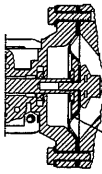
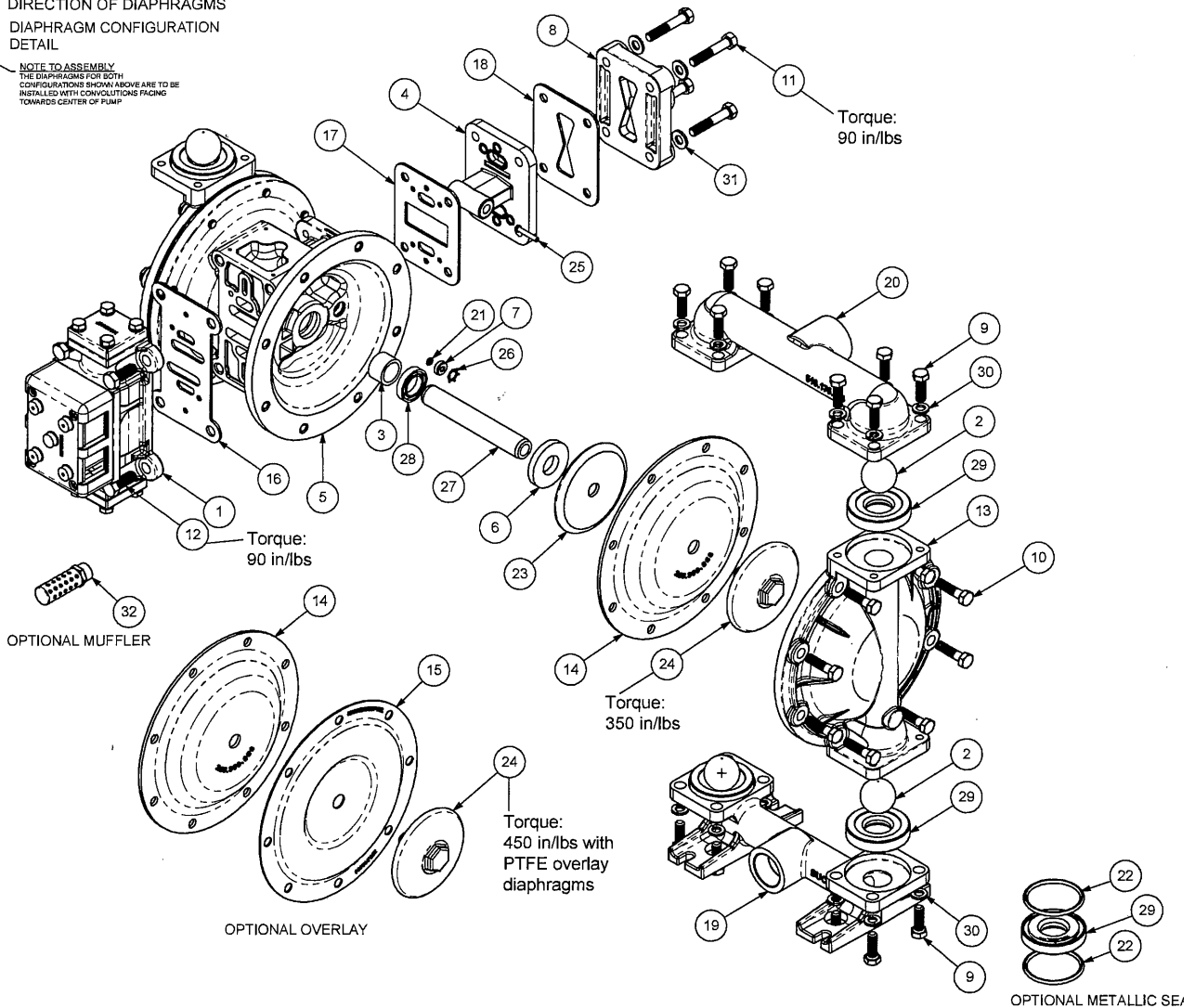

ILLUSTRATION SHOWS DIRECTION OF DIAPHRAGMS DIAPHRAGM CONFIGURATION DETAIL

NOTE TO ASSEMBLY: THE DIAPHRAGMS FOR BOTH CONFIGURATIONS SHOWN ABOVE ARE TO BE INSTALLED WITH CONVOLUTIONS FACING TOWARDS CENTER OF PUMP



Service & Repair Kits

- 476-228-000 Air End Kit (Aluminum Center)**
Seals, O-Ring, Gaskets, Retaining Rings, Air Valve Sleeve and Spool Set, and Pilot Valve Assembly.
- 476-201-000 Air End Kit**
(Air Valve with Stroke Indicator Pin, Aluminum Center)
Seals, O-Ring, Gaskets, Retaining Rings, Air Valve Sleeve and Spool Set, and Pilot Valve Assembly.
- 476-194-354 Wet End Kit**
Santoprene Diaphragms, Balls and Polyethylene Seats.
- 476-194-360 Wet End Kit**
Nitrile Diaphragms, Balls, and Polyethylene Seats.
- 476-194-365 Wet End Kit**
Neoprene Diaphragms, Balls, and Polyethylene Seats.
- 476-194-633 Wet End Kit**
FKM Diaphragms, PTFE Overlay, PTFE Balls and Seats.

- 476-194-635 Wet End Kit**
Neoprene Diaphragms, PTFE Overlay Balls and Seats.
- 476-194-654 Wet End Kit**
Santoprene Diaphragms, PTFE Overlay, PTFE Balls, PTFE Seats.
- 476-194-661 Wet End Kit**
EPDM Diaphragms, Santoprene Balls and Polyethylene Seats.
- 476-194-659 Wet End Kit**
One-Piece Bonded PTFE/Nitrile Diaphragm, PTFE Balls, PTFE Seats.
- Hardware Kits**
- 475-212-330** Zinc Plated Capscrews, Washers, and Hex Nuts.
- 475-212-115** Stainless Steel Capscrews, Washers, and Hex Nuts.

Composite Repair Parts List

Item	Part Number	Description	Qty	Item	Part Number	Description	Qty
①	▲ 031-179-000	Air Valve Assembly (Cast Iron Centers Only)	1	20	518-176-156	Manifold, Discharge	1
	▲ 031-146-000	Air Valve Assembly (Stroke Indicator)	1		518-176-156E	Manifold, Discharge 1" (BSP Tapered)	1
	▲ 031-147-000	Air Valve Assembly (Stroke Indicator)	1		518-176-010	Manifold, Discharge	1
	▲ 031-183-000	Air Valve Assembly	1		518-176-010E	Manifold, Discharge 1" (BSP Tapered)	1
	▲ 031-183-001	Air Valve Assembly (W/Stainless Steel Hardware)	1		518-176-110	Manifold, Discharge	1
	031-173-000	Air Valve Assembly (W/ Aluminum centers only)	1		518-176-110E	Manifold, Discharge 1" (BSP Tapered)	1
	031-173-001	Air Valve Assembly (W/ Stainless Steel Hardware only)	1	21	560-001-360	O-Ring	2
	031-140-000	Air Valve Assembly w/Integral muffler (Cast Iron Centers Only)	1	22	560-091-360	Seal (Check Valve) (See item 29)	8
	031-141-000	Air Valve Assembly (Cast Iron Centers Only)	1		560-091-363	Seal (Check Valve) (See item 29)	8
2	050-028-354	Ball, Check	4		560-091-364	Seal (Check Valve) (See item 29)	8
	050-028-360	Ball, Check	4		560-091-365	Seal (Check Valve) (See item 29)	8
	050-028-365	Ball, Check	4		560-091-611	Seal (Check Valve) (See item 29)	8
	050-028-600	Ball, Check	4	23	612-022-330	Plate, Inner Diaphragm	2
3	070-012-170	Bushing	2		612-218-330	Plate, Inner Diaphragm (use with One-Piece Bonded)	2
4	095-110-000	Pilot Valve Assembly	1	24	612-108-157	Plate, Outer Diaphragm Assembly	2
	095-110-558	Pilot Valve Assembly (Cast Iron Centers Only)	1		612-101-082	Plate, Outer Diaphragm Assembly	2
5	114-025-157	Intermediate	1		612-101-110	Plate, Outer Diaphragm Assembly	2
	114-025-010	Intermediate	1	25	620-022-115	Pin, Actuator	2
6	132-019-360	Bumper	2	26	675-042-115	Ring, Retaining	2
7	135-036-506	Bushing	2	27	685-060-120	Rod, Diaphragm	1
8	165-120-157	Cap, Air Inlet Assembly	1	28	720-010-375	Seal, U-Cup	2
	165-120-010	Cap, Air Inlet Assembly	1	29	722-098-550	Seat, Check Ball	4
9	170-044-115	Capscrew, Hex Hd 5/16-18 X 1.00	16		722-098-080	Seat, Check Ball (seals required see item 22)	4
	170-044-330	Capscrew, Hex Hd 5/16-18 X 1.00	16		722-098-110	Seat, Check Ball (seals required see item 22)	4
10	170-045-115	Capscrew, Hex Hd 5/16-18 X 1.25	16		722-098-150	Seat, Check Ball (seals required see item 22)	4
	170-045-330	Capscrew, Hex Hd 5/16-18 X 1.25	16		722-098-600	Seat, Check Ball (seals required see item 22)	4
11	170-069-115	Capscrew, Hex Hd 5/16-18 X 1.75	4	30	900-004-330	Lock Washer, 5/16	16
	170-069-330	Capscrew, Hex Hd 5/16-18 X 1.75	4		900-004-115	Lock Washer, 5/16	16
12	171-053-115	Capscrew, Hex Soc 3/8-16 X 2.50 (Stroke Indicator option only)	4	31	901-038-330	Flat Washer, 5/16	4
	171-053-330	Capscrew, Hex Soc 3/8-16 X 2.50 (Stroke Indicator option only)	4		901-038-115	Flat Washer, 5/16	4
	170-006-115	Capscrew, Hex HD 3/8-16 X 1.00	4	32	▲ 530-033-000	Muffler, Metal	1
	170-006-330	Capscrew, Hex HD 3/8-16 X 1.00	4				
13	196-173-156/157	Chamber, Outer	2				
	196-173-010	Chamber, Outer	2				
	196-173-110	Chamber, Outer	2				
14	286-008-354	Diaphragm	2				
	286-008-360	Diaphragm	2				
	286-008-363	Diaphragm	2				
	286-008-364	Diaphragm	2				
	286-008-365	Diaphragm	2				
	286-112-000	Diaphragm, One-Piece Bonded	2				
15	286-015-604	Diaphragm, Overlay	2				
16	360-093-360	Gasket, Air Valve	1				
17	360-103-360	Gasket, Pilot Valve	1				
18	360-104-379	Gasket, Air Inlet Cap	1				
19	518-175-156	Manifold, Suction	1				
	518-175-156E	Manifold, Suction 1" BSP Tapered	1				
	518-175-010	Manifold, Suction	1				
	518-175-010E	Manifold, Suction 1" (BSP Tapered)	1				
	518-175-110	Manifold, Suction	1				
	518-175-110E	Manifold, Suction 1" (BSP Tapered)	1				

Parts not shown used with Raised Face Flange Porting Option

170-044-330	Hex Cap Screw	4
326-050-080	Mounting Bracket	2
334-112-110	1" Raised Face, 150# ANSI Flange	2
538-035-110	Pipe Nipple 1" NPT x 1 1/2"	2
545-004-330	Hex Nut	4
900-004-330	Lock Washer	4
901-009-330	Flat Washer	8

LEGEND:

- = Items contained within Air End Kits
- = Items contained within Wet End Kits

Note: Kits contain components specific to the material codes.

 **ATEX Compliant**

Material Codes - The Last 3 Digits of Part Number

- 000.....Assembly, sub-assembly;
and some purchased items
 - 010.....Cast Iron
 - 015.....Ductile Iron
 - 020.....Ferritic Malleable Iron
 - 080.....Carbon Steel, AISI B-1112
 - 110.....Alloy Type 316 Stainless Steel
 - 111.....Alloy Type 316 Stainless Steel
(Electro Polished)
 - 112.....Alloy C
 - 113.....Alloy Type 316 Stainless Steel
(Hand Polished)
 - 114.....303 Stainless Steel
 - 115.....302/304 Stainless Steel
 - 117.....440-C Stainless Steel (Martensitic)
 - 120.....416 Stainless Steel
(Wrought Martensitic)
 - 148.....Hardcoat Anodized Aluminum
 - 150.....6061-T6 Aluminum
 - 152.....2024-T4 Aluminum (2023-T351)
 - 155.....356-T6 Aluminum
 - 156.....356-T6 Aluminum
 - 157.....Die Cast Aluminum Alloy #380
 - 158.....Aluminum Alloy SR-319
 - 162.....Brass, Yellow, Screw Machine Stock
 - 165.....Cast Bronze, 85-5-5-5
 - 166.....Bronze, SAE 660
 - 170.....Bronze, Bearing Type,
Oil Impregnated
 - 180.....Copper Alloy
 - 305.....Carbon Steel, Black Epoxy Coated
 - 306.....Carbon Steel, Black PTFE Coated
 - 307.....Aluminum, Black Epoxy Coated
 - 308.....Stainless Steel, Black PTFE Coated
 - 309.....Aluminum, Black PTFE Coated
 - 313.....Aluminum, White Epoxy Coated
 - 330.....Zinc Plated Steel
 - 332.....Aluminum, Electroless Nickel Plated
 - 333.....Carbon Steel, Electroless
Nickel Plated
 - 335.....Galvanized Steel
 - 337.....Silver Plated Steel
 - 351.....Food Grade Santoprene®
 - 353.....Geolast; Color: Black
 - 354.....Injection Molded #203-40
Santoprene® Duro 40D +/-5;
Color: RED
 - 356.....Hytrel®
 - 357.....Injection Molded Polyurethane
 - 358.....Urethane Rubber
(Some Applications)
(Compression Mold)
 - 359.....Urethane Rubber
 - 360.....Nitrile Rubber Color coded: RED
 - 363.....FKM (Fluorocarbon)
Color coded: YELLOW
 - 364.....EPDM Rubber
Color coded: BLUE
 - 365.....Neoprene Rubber
Color coded: GREEN
 - 366.....Food Grade Nitrile
 - 368.....Food Grade EPDM
 - 371.....Phlithane (Tuftane)
 - 374.....Carboxylated Nitrile
 - 375.....Fluorinated Nitrile
 - 378.....High Density Polypropylene
 - 379.....Conductive Nitrile
 - 408.....Cork and Neoprene
 - 425.....Compressed Fibre
 - 426.....Blue Gard
 - 440.....Vegetable Fibre
 - 500.....Delrin® 500
 - 502.....Conductive Acetal, ESD-800
 - 503.....Conductive Acetal, Glass-Filled
 - 506.....Delrin® 150
 - 520.....Injection Molded PVDF
Natural color
 - 540.....Nylon
 - 542.....Nylon
 - 544.....Nylon Injection Molded
 - 550.....Polyethylene
 - 551.....Glass Filled Polypropylene
 - 552.....Unfilled Polypropylene
 - 555.....Polyvinyl Chloride
 - 556.....Black Vinyl
 - 558.....Conductive HDPE
 - 570.....Rulon II®
 - 580.....Ryton®
 - 600.....PTFE (virgin material)
Tetrafluorocarbon (TFE)
 - 603.....Blue Gylon®
 - 604.....PTFE
 - 606.....PTFE
 - 607.....Envelon
 - 608.....Conductive PTFE
 - 610.....PTFE Encapsulated Silicon
 - 611.....PTFE Encapsulated FKM
 - 632.....Neoprene/Hytrel®
 - 633.....FKM/PTFE
 - 634.....EPDM/PTFE
 - 635.....Neoprene/PTFE
 - 637.....PTFE, FKM/PTFE
 - 638.....PTFE, Hytrel®/PTFE
 - 639.....Nitrile/TFE
 - 643.....Santoprene®/EPDM
 - 644.....Santoprene®/PTFE
 - 656.....Santoprene® Diaphragm and
Check Balls/EPDM Seats
 - 661.....EPDM/Santoprene®
 - 666.....FDA Nitrile Diaphragm,
PTFE Overlay, Balls, and Seals
 - 668.....PTFE, FDA Santoprene®/PTFE
- Delrin and Hytrel are registered tradenames of E.I. DuPont.
 - Nylatron is a registered tradename of Polymer Corp.
 - Gylon is a registered tradename of Garlock, Inc.
 - Santoprene is a registered tradename of Exxon Mobil Corp.
 - Rulon II is a registered tradename of Dixon Industries Corp.
 - Ryton is a registered tradename of Phillips Chemical Co.
 - Valox is a registered tradename of General Electric Co.

3: EXP VIEW

RECYCLING

Many components of SANDPIPER® AODD pumps are made of recyclable materials. We encourage pump users to recycle worn out parts and pumps whenever possible, after any hazardous pumped fluids are thoroughly flushed.

Air Distribution Valve Assembly

(Use With Aluminum Centers Only)

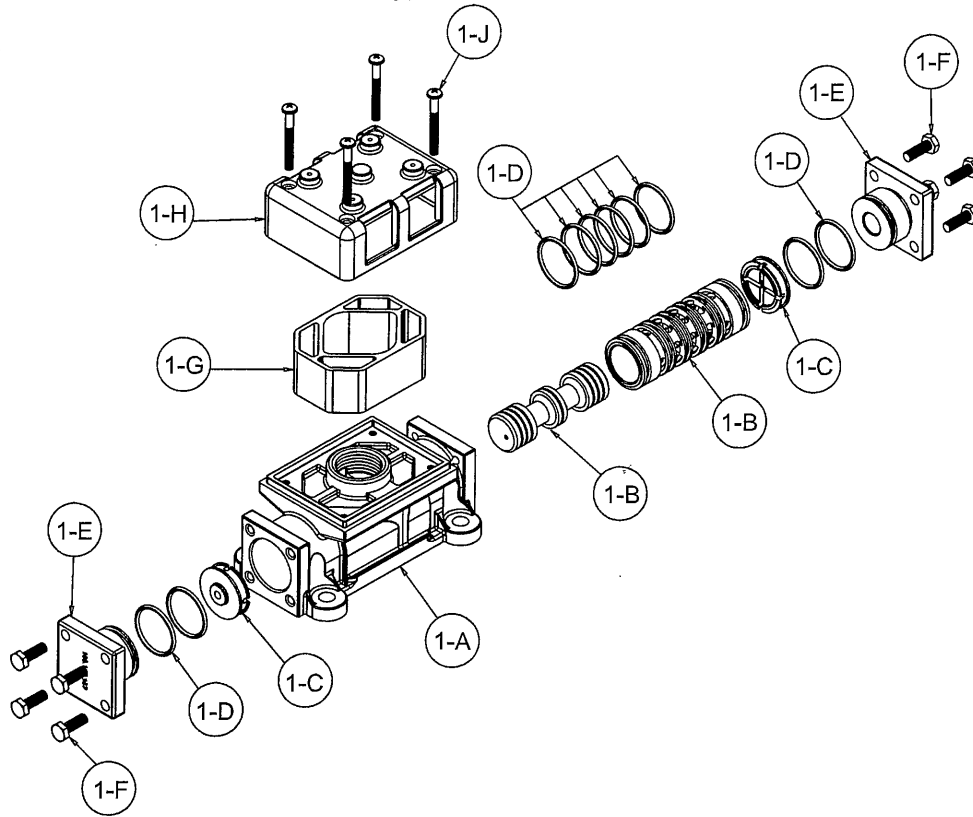

Air Distribution Valve Servicing

See repair parts drawing, remove screws.

Step 1: Remove hex cap screws (1-F).

Step 2: Remove end cap (1-E) and bumper (1-C).

Step 3: Remove spool part of (1-B) (caution: do not scratch).

Step 4: Press sleeve (1-B) from body (1-A).

Step 5: Inspect O-Rings (1-D) and replace if necessary.

Step 6: Lightly lubricate O-Rings (1-D) on sleeve (1-B).

Step 7: Press sleeve (1-B) into body (1-A).

Step 8: Reassemble in reverse order, starting with step 3.

Note: Sleeve and spool (1-B) set is match ground to a specified clearance sleeve and spools (1-B) cannot be interchanged.

IMPORTANT



Read these instructions completely, before installation and start-up. It is the responsibility of the purchaser to retain this manual for reference. Failure to comply with the recommendations stated in this manual will damage the pump, and void factory warranty.



ATEX Compliant

**Air Valve Assembly Parts List

Item	Part Number	Description	Qty
1	031-173-000	Air Valve Assembly	1
1-A	095-109-157	Body, Air Valve	1
1-B	031-139-000	Sleeve and Spool Set	1
1-C	132-029-357	Bumper	2
1-D	560-020-360	O-Ring	10
1-E	165-127-157	Cap, End	2
1-F	170-032-330	Hex Head Capscrew 1/4-20 x .75	8
1-G	530-028-550	Muffler	1
1-H	165-096-551	Muffler Cap	1
1-J	706-026-330	Machine Screw	4

**Air Valve Assembly Parts List

1	031-173-001	Air Valve Assembly	1
---	-------------	--------------------	---

Consists of all components above except:

1-F	170-032-115	Hex Head Capscrew 1/4-20 x .75	8
1-J	706-026-115	Machine Screw	4

****Note:** Pumps equipped with these Valve Assemblies are not ATEX compliant.

Air Distribution Valve Assembly

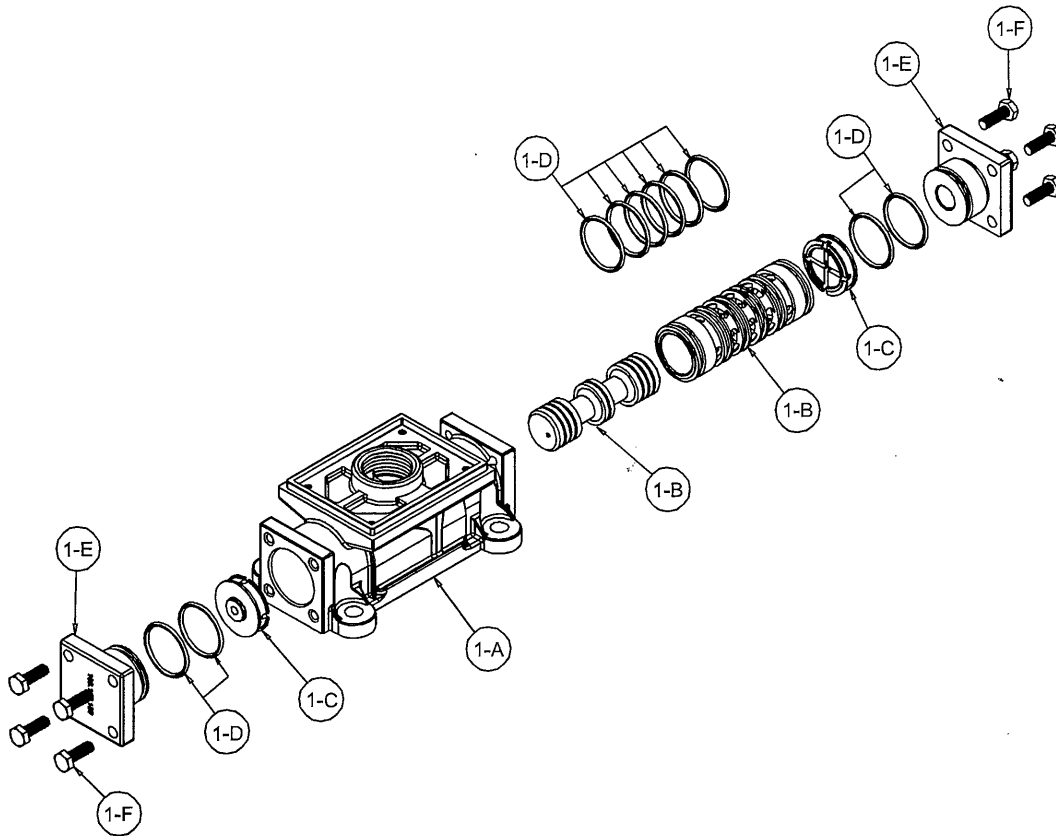

Air Distribution Valve Servicing

See repair parts drawing, remove screws.

Step 1: Remove hex cap screws (1-F).

Step 2: Remove end cap (1-E) and bumper (1-C).

Step 3: Remove spool part of (1-B) (caution: do not scratch).

Step 4: Press sleeve (1-B) from body (1-A).

Step 5: Inspect O-Rings (1-D) and replace if necessary.

Step 6: Lightly lubricate O-Rings (1-D) on sleeve (1-B).

Step 7: Press sleeve (1-B) into body (1-A).

Step 8: Reassemble in reverse order, starting with step 3.

Note: Sleeve and spool (1-B) set is match ground to a specified clearance sleeve and spools (1-B) cannot be interchanged.

Air Valve Assembly Parts List

(Use w/Aluminum center sections)

Item	Part Number	Description	Qty
▲ 1	031-183-000	Air Valve Assembly	1
1-A	095-109-157	Body, Air Valve	1
1-B	031-139-000	Sleeve and Spool Set	1
1-C	132-029-357	Bumper	2
1-D	560-020-360	O-Ring	10
1-E	165-127-157	Cap, End	2
1-F	170-032-330	Hex Head Capscrew 1/4-20 x .75	8

Air Valve Assembly Parts List

▲ 1	031-183-001	Air Valve Assembly	1
Consists of all components above except:			
1-F	170-032-115	Hex Head Capscrew 1/4-20 x .75	8

▲ IMPORTANT



Read these instructions completely, before installation and start-up. It is the responsibility of the purchaser to retain this manual for reference. Failure to comply with the recommendations stated in this manual will damage the pump, and void factory warranty.



ATEX Compliant

Air Distribution Valve Assembly

(Use With Cast Iron Centers Only)

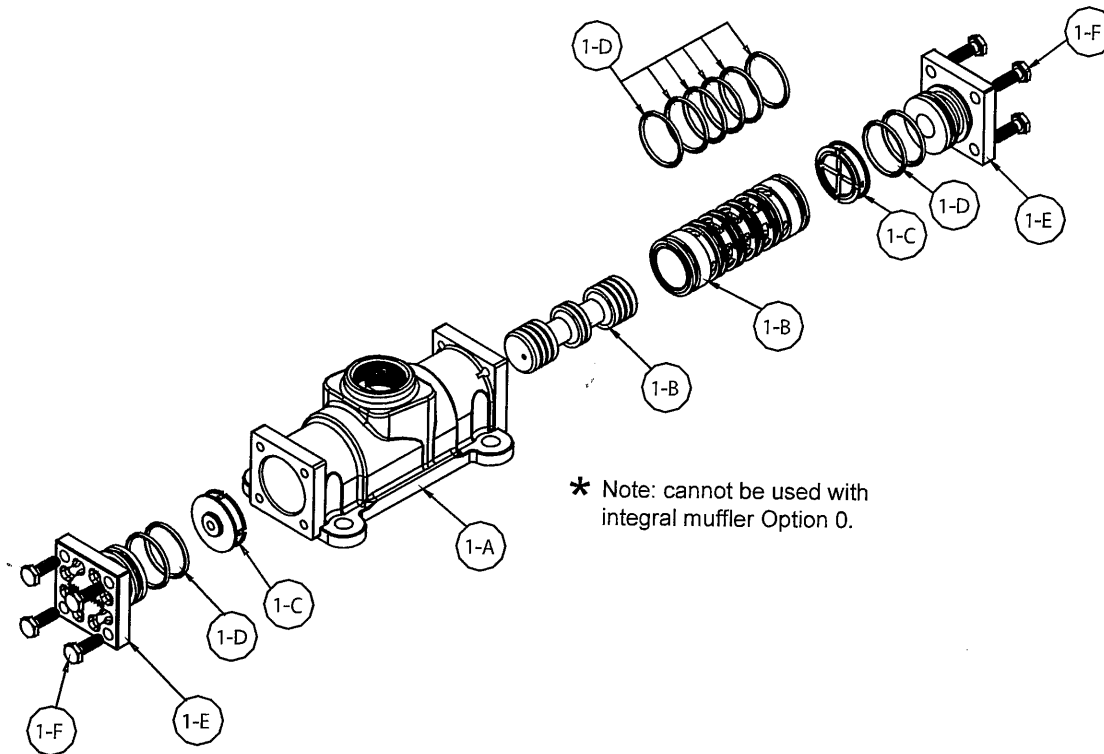

* Note: cannot be used with integral muffler Option 0.

Air Distribution Valve Servicing

See repair parts drawing, remove screws.

Step 1: Remove hex cap screws (1-F).

Step 2: Remove end cap (1-E) and bumper (1-C).

Step 3: Remove spool part of (1-B) (caution: do not scratch).

Step 4: Press sleeve (1-B) from body (1-A).

Step 5: Inspect O-Rings (1-D) and replace if necessary.

Step 6: Lightly lubricate O-Rings (1-D) on sleeve (1-B).

Step 7: Press sleeve (1-B) into body (1-A).

Step 8: Reassemble in reverse order, starting with step 3.

Note: Sleeve and spool (1-B) set is match ground to a specified clearance sleeve and spools (1-B) cannot be interchanged.

Air Valve Assembly Parts List

Item	Part Number	Description	Qty
1	031-179-000	Gas Valve Assembly	1
1-A	095-109-110 *	Valve Body	1
1-B	031-139-000	Sleeve and Spool Set	1
1-C	132-029-357	Bumper	2
1-D	560-020-360	O-Ring	10
1-E	165-127-110	Cap, End	2
1-F	170-032-115	Capscrew	8

IMPORTANT



Read these instructions completely, before installation and start-up. It is the responsibility of the purchaser to retain this manual for reference. Failure to comply with the recommendations stated in this manual will damage the pump, and void factory warranty.



ATEX Compliant

Air Distribution Valve Assembly

(For NON-ATEX Cast Iron Centers)

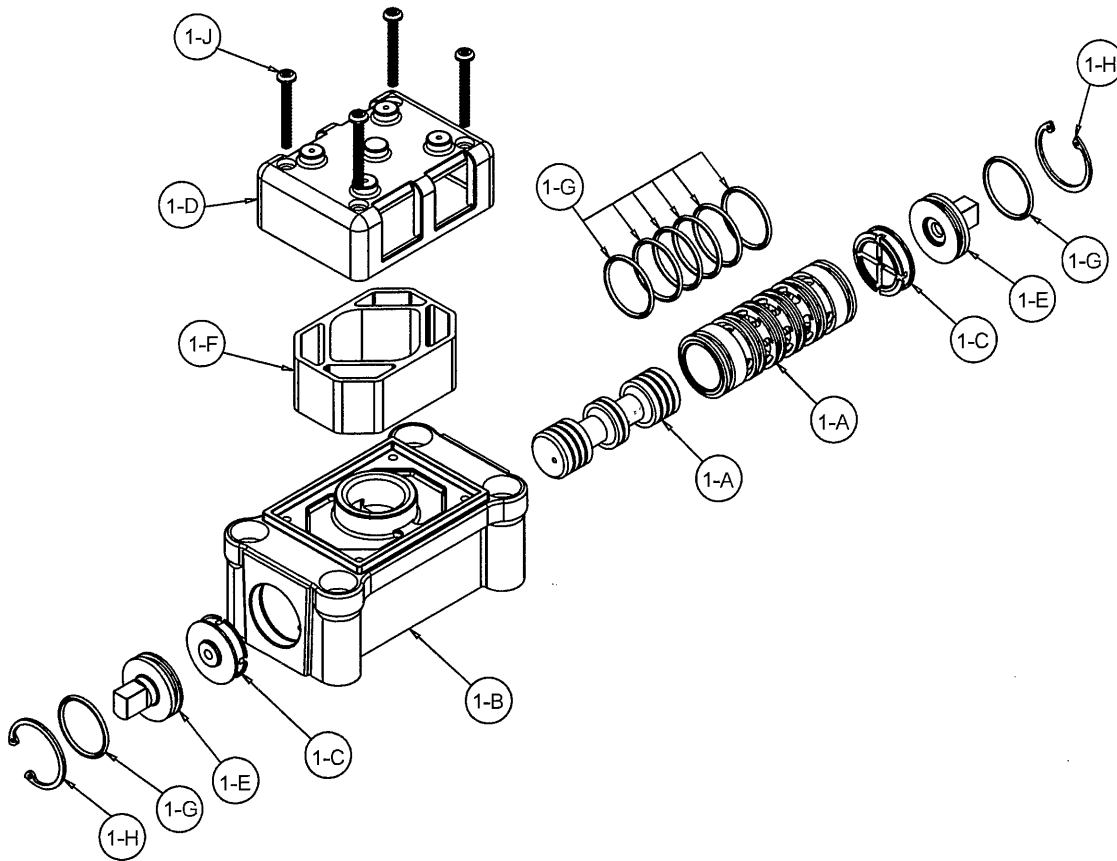

Air Distribution Valve Servicing

See repair parts drawing, remove screws.

Step 1: Remove end cap retainer (1-H).

Step 2: Remove end cap (1-E).

Step 3: Remove spool part of (1-A) (caution: do not scratch).

Step 4: Press sleeve (1-A) from body (1-B).

Step 5: Inspect O-Ring (1-H) and replace if necessary.

Step 6: Lightly lubricate O-Rings (1-H) on sleeve (1-A).

Step 7: Press sleeve (1-A) into body (1-B).

Step 8: Reassemble in reverse order, starting with step 3.

Note: Sleeve and spool (1-A) set is match ground to a specified clearance sleeve and spools (1-A) cannot be interchanged.

Air Valve Assembly Parts List

Item	Part Number	Description	Qty
1	031-140-000	Air Valve Assembly	1
1-A	031-139-000	Sleeve and Spool Set	1
1-B	095-094-551	Body, Air Valve	1
1-C	132-029-552	Bumper	2
1-D	165-096-551	Cap, Muffler	1
1-E	165-115-552	Cap, End	2
1-F	530-028-550	Muffler	1
1-G	560-020-360	O-Ring	8
1-H	675-044-115	Ring, Retaining	2
1-J	710-015-115	Screw, Self-tapping	4

For Pumps with Alternate Mesh, Sound Dampening Mufflers or Piped Exhaust:

1	031-141-000	Air Valve Assembly	1
(Includes all items used on 031-140-000 minus items 1-D, 1-F & 1-J)			

IMPORTANT



Read these instructions completely, before installation and start-up. It is the responsibility of the purchaser to retain this manual for reference. Failure to comply with the recommendations stated in this manual will damage the pump, and void factory warranty.

Air Valve with Stroke Indicator Assembly

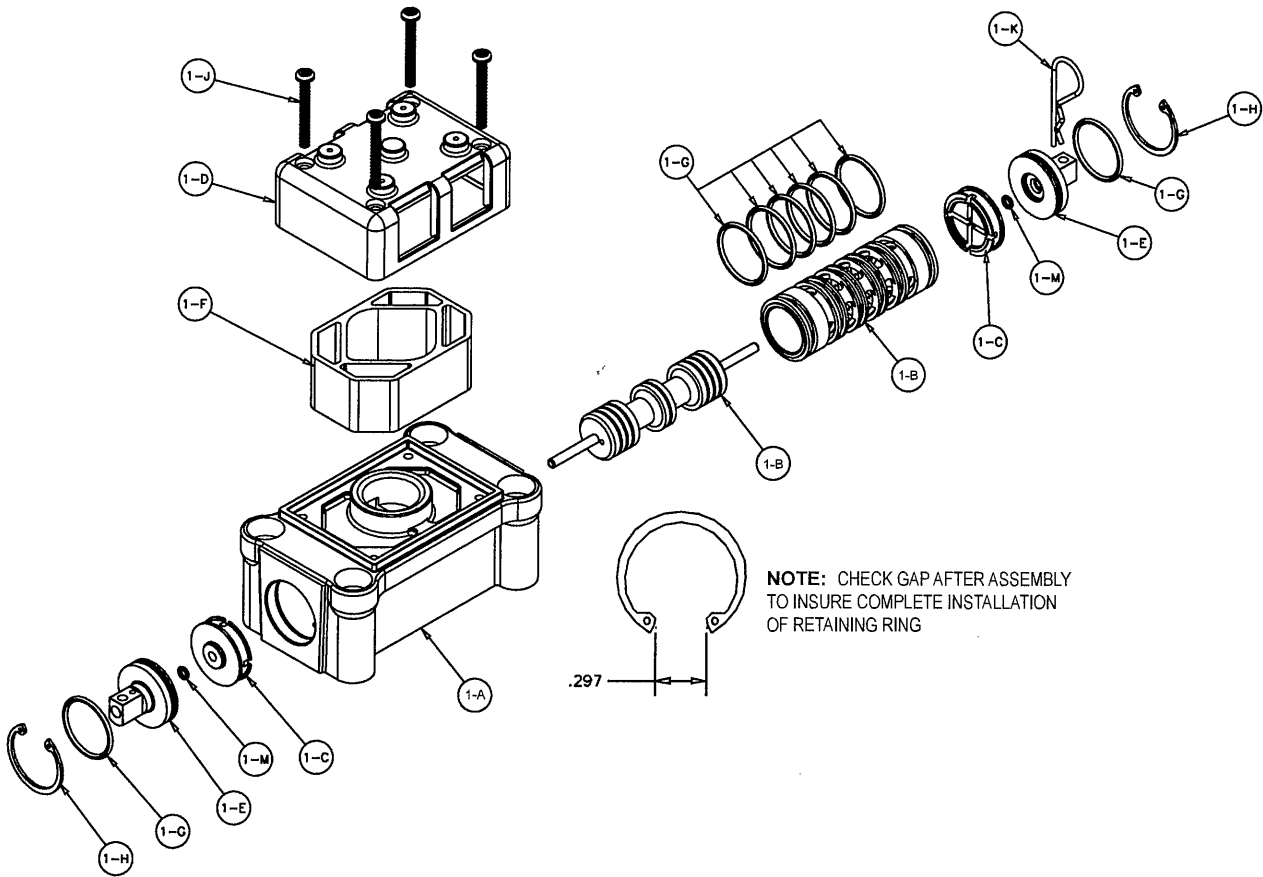

AIR END

Air Distribution Valve Servicing

See repair parts drawing, remove screws.

Step 1: Remove end cap retainer (1-H).

Step 2: Remove end cap (1-E), bumper (1-C).

Step 3: Remove spool part of (1-B) (caution, do not scratch).

Step 4: Press sleeve (1-B) from body (1-A).

Step 5: Inspect O-Rings (1-G) and replace if necessary.

Step 6: Lightly lubricate O-Rings (1-G) on sleeve (1-B).

Step 7: Press sleeve (1-B) into body (1-A).

Step 8: Reassemble in reverse order.

Note: Sleeve and spool (1-B) set is match ground to a specified clearance sleeve and spools (1-B) cannot be interchanged.

Air Valve Assembly Parts List

Item	Part Number	Description	Qty
1	031-146-000	Air Valve Assembly	1
1-A	031-143-000	Sleeve and Spool Set	1
1-B	095-094-559	Body, Air Valve	1
1-C	132-029-552	Bumper	2
1-D	165-096-559	Cap, Muffler	1
1-E	165-098-147	Cap, End	2
1-F	530-028-550	Muffler	1
1-G	560-020-360	O-Ring	8
1-H	675-044-115	Ring, Retaining	2
1-J	710-015-115	Screw, Self Tapping	4
1-K	210-008-330	Clip, Safety	1
1-M	560-029-360	O-Ring	2

For Pumps with Alternate Mesh, Sound Dampening Mufflers or Piped Exhaust:

1	031-147-000	Air Valve Assembly	1
----------	--------------------	---------------------------	----------

(includes all items on 031-146-000 minus 1-D, 1-F, & 1-J).

Ex **ATEX Compliant**

Pilot Valve Assembly

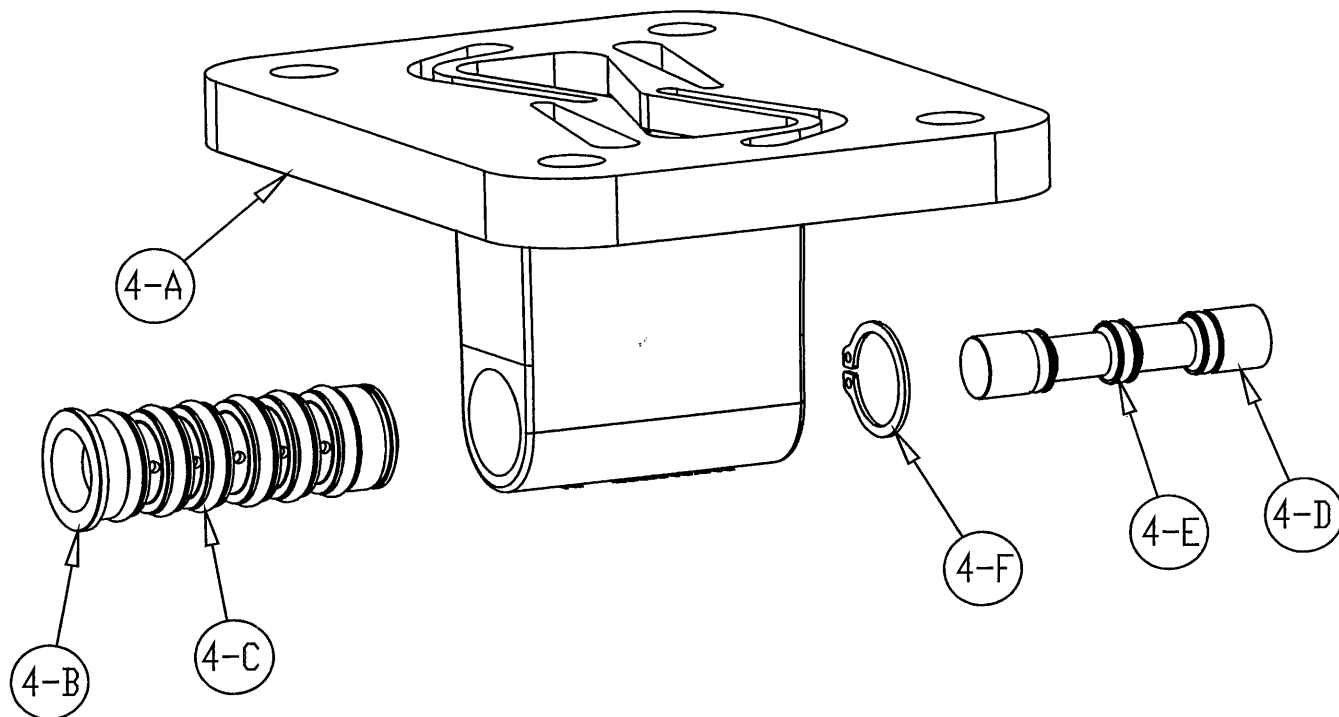

Pilot Valve Servicing

With Pilot Valve removed from pump.

Step 1: Remove snap ring (4-F).

Step 2: Remove sleeve (4-B), inspect O-Rings (4-C), replace if required.

Step 3: Remove spool (4-D) from sleeve (4-B), inspect O-Rings (4-E), replace if required.

Step 4: Lightly lubricate O-Rings (4-C) and (4-E).

Reassemble in reverse order.

Pilot Valve Assembly Parts List

Item	Part Number	Description	Qty
4	095-110-000	Pilot Valve Assembly	1
4-A	095-095-157	Valve Body	1
4-B	755-052-000	Sleeve (With O-Rings)	1
4-C	560-033-360	O-Ring (Sleeve)	6
4-D	775-055-000	Spool (With O-Rings)	1
4-E	560-023-360	O-Ring (Spool)	3
4-F	675-037-080	Retaining Ring	1

For Pumps with Cast Iron Center Section

Item	Part Number	Description	Qty
4	095-110-558	Pilot Valve Assembly	1
4-A	095-095-558	Valve Body	1

(includes all other items used on 095-110-000)

 **ATEX Compliant**

Intermediate Assembly

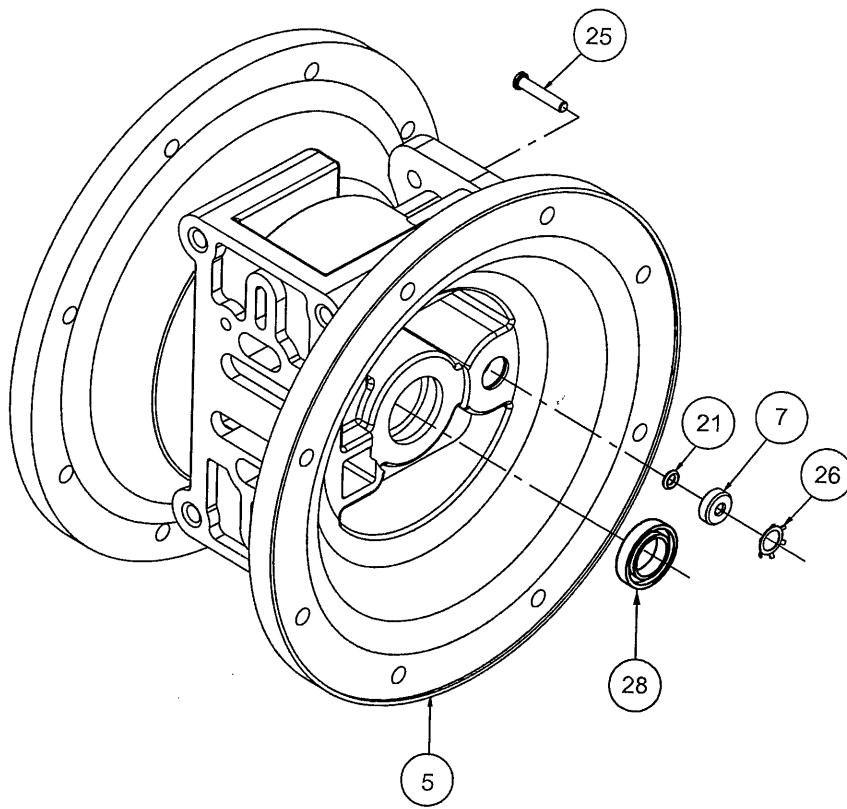

Intermediate Assembly Drawing

- Step 1:** Remove plunger, actuator (25) from center of intermediate pilot valve cavity.
- Step 2:** Remove Ring, Retaining (26), discard.
- Step 3:** Remove bushing, plunger (7), inspect for wear and replace if necessary with genuine parts.
- Step 4:** Remove O-Ring (21), inspect for wear and replace if necessary with genuine parts.
- Step 5:** Lightly lubricate O-Ring (21) and insert into intermediate.
- Step 6:** Utilizing a new Ring, Retaining (26) reassemble in reverse order
- Step 7:** Remove Seal, Diaphragm Rod (28).
- Step 8:** Clean seal area, lightly lubricate and install new Seal, Diaphragm Rod (28).

Intermediate Assembly Parts List

Item	Part Number	Description	Qty
5	114-025-157	Intermediate	1
	114-025-010	Intermediate	1
7	135-036-506	Bushing, Plunger*	2
21	560-001-360	O-Ring	2
25	620-022-115	Plunger, Actuator*	2
26	675-042-115	Ring, Retaining	2
28	720-010-375	Seal, Diaphragm Rod*	2

IMPORTANT



When the pumped product source is at a higher level than the pump (flooded suction condition), pipe the exhaust higher than the product source to prevent siphoning spills. In the event of a diaphragm failure a complete rebuild of the center section is recommended.

Diaphragm Service Drawing, with Overlay

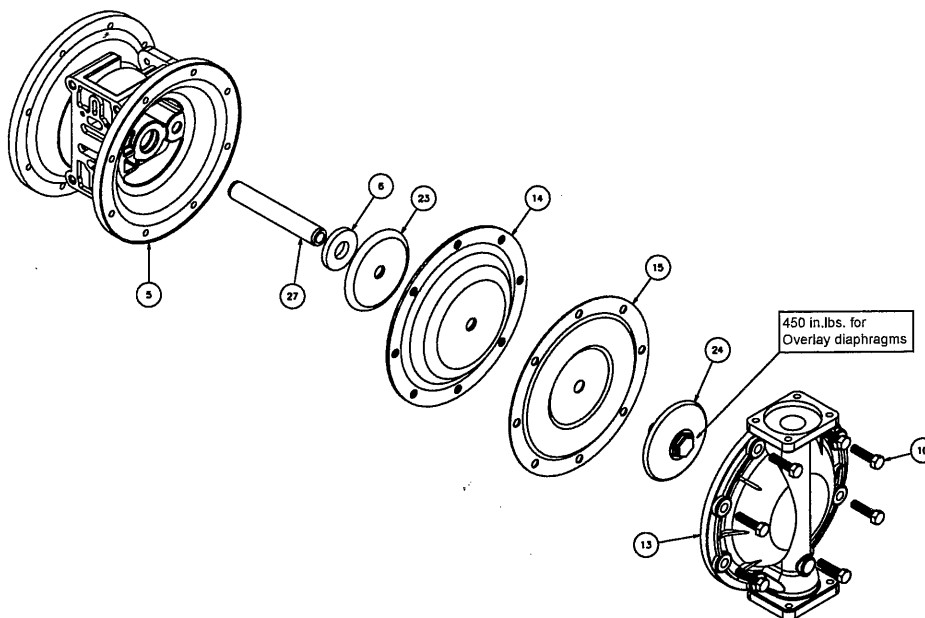

Diaphragm Service Drawing, Non-Overlay

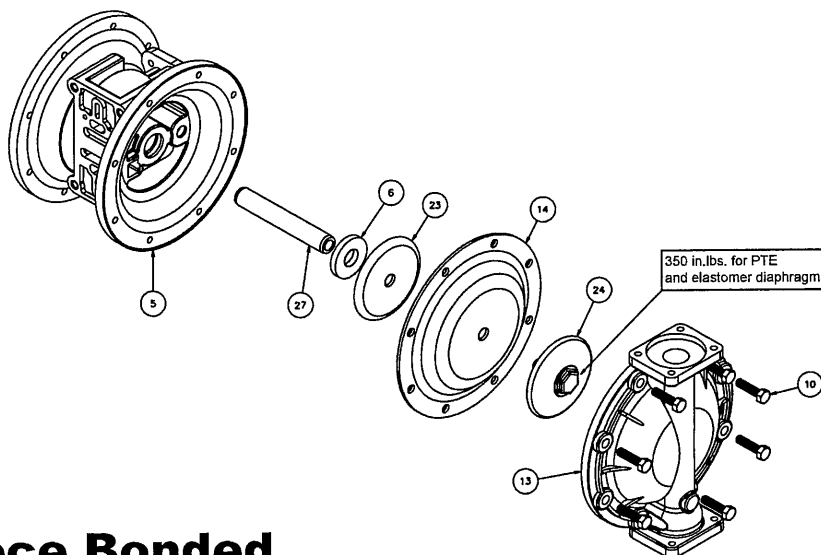

5: WET END

One-Piece Bonded *Diaphragm Service Drawing

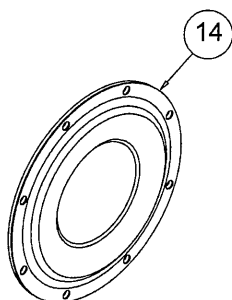

*Available For Field Conversion From Overlay To One-Piece Bonded Diaphragm Kits:

Kit:	475-250-000	
2	286-112-000	One-Piece Diaphragm
2	612-218-330	Inner Plates

Diaphragm Servicing

Step 1: With manifolds and outer chambers removed, remove diaphragm assemblies from diaphragm rod. **DO NOT** use a pipe wrench or similar tool to remove assembly from rod. Flaws in the rod surface may damage bearings and seal. Soft jaws in a vise are recommended to prevent diaphragm rod damage.

Step 1.A: NOTE: Not all inner diaphragm plates are threaded. Some models utilize a through hole in the inner diaphragm plate. If required to separate diaphragm assembly, place assembly in a vise, gripping on the exterior cast diameter of the inner plate. Turn the outer plate clockwise to separate the assembly.

Always inspect diaphragms for wear cracks or chemical attack. Inspect inner and outer plates for deformities, rust scale and wear. Inspect intermediate bearings for elongation and wear. Inspect diaphragm rod for wear or marks.

Clean or repair if appropriate. Replace as required.

Step 2: Reassembly: There are two different types of diaphragm plate assemblies utilized throughout the Sandpiper product line: Outer plate with a threaded stud, diaphragm, and a threaded inner plate.

Outer plate with a threaded stud, diaphragm, and an inner plate with through hole. Secure threaded inner plate in a vise. Ensure that the plates are being installed with the outer radius against the diaphragm.

Step 3: Lightly lubricate, with a compatible material, the inner faces of both outer and inner diaphragm plates when using on non Overlay diaphragms (For EPDM water is recommended). No lubrication is required.

Step 4: Push the threaded outer diaphragm plate through the center hole of the diaphragm.

Note: Most diaphragms are installed with the natural bulge out towards the fluid side. S05, S07, and S10 non-metallic units are installed with the natural bulge in towards the air side.

Step 5: Thread or place, outer plate stud into the inner plate. For threaded inner plates, use a torque wrench to tighten the assembly together. Torque values are called out on the exploded view.

Repeat procedure for second side assembly. Allow a minimum of 15 minutes to elapse after torquing, then re-torque the assembly to compensate for stress relaxation in the clamped assembly.

Step 6: Thread one assembly onto the diaphragm rod with sealing washer (when used) and bumper.

Step 7: Install diaphragm rod assembly into pump and secure by installing the outer chamber in place and tightening the capscrews.

Step 8: On opposite side of pump, thread the remaining assembly onto the diaphragm rod. Using a torque wrench, tighten the assembly to the diaphragm rod. Align diaphragm through bolt holes, always going forward past the recommended torque. Torque values are called out on the exploded view. **NEVER** reverse to align holes, if alignment cannot be achieved without damage to diaphragm, loosen complete assemblies, rotate diaphragm and reassemble as described above.

Step 9: Complete assembly of entire unit.

One Piece Diaphragm Servicing (Bonded PTFE with integral plate) The One Piece diaphragm has a threaded stud installed in the integral plate at the factory. The inner diaphragm plate has a through hole instead of a threaded hole. Place the inner plate over the diaphragm stud and thread the first diaphragm / inner plate onto the diaphragm rod only until the inner plate contacts the rod. Do not tighten. A small amount of grease may be applied between the inner plate and the diaphragm to facilitate assembly. Insert the diaphragm / rod assembly into the pump and install the outer chamber. Turn the pump over and thread the second diaphragm / inner plate onto the diaphragm rod. Turn the diaphragm until the inner plate contacts the rod and hand tighten the assembly. Continue tightening until the bolt holes align with the inner chamber holes. **DO NOT LEAVE THE ASSEMBLY LOOSE.**

5: WET END

IMPORTANT



Read these instructions completely, before installation and start-up. It is the responsibility of the purchaser to retain this manual for reference. Failure to comply with the recommendations stated in this manual will damage the pump, and void factory warranty.

Solenoid Shifted Air Valve

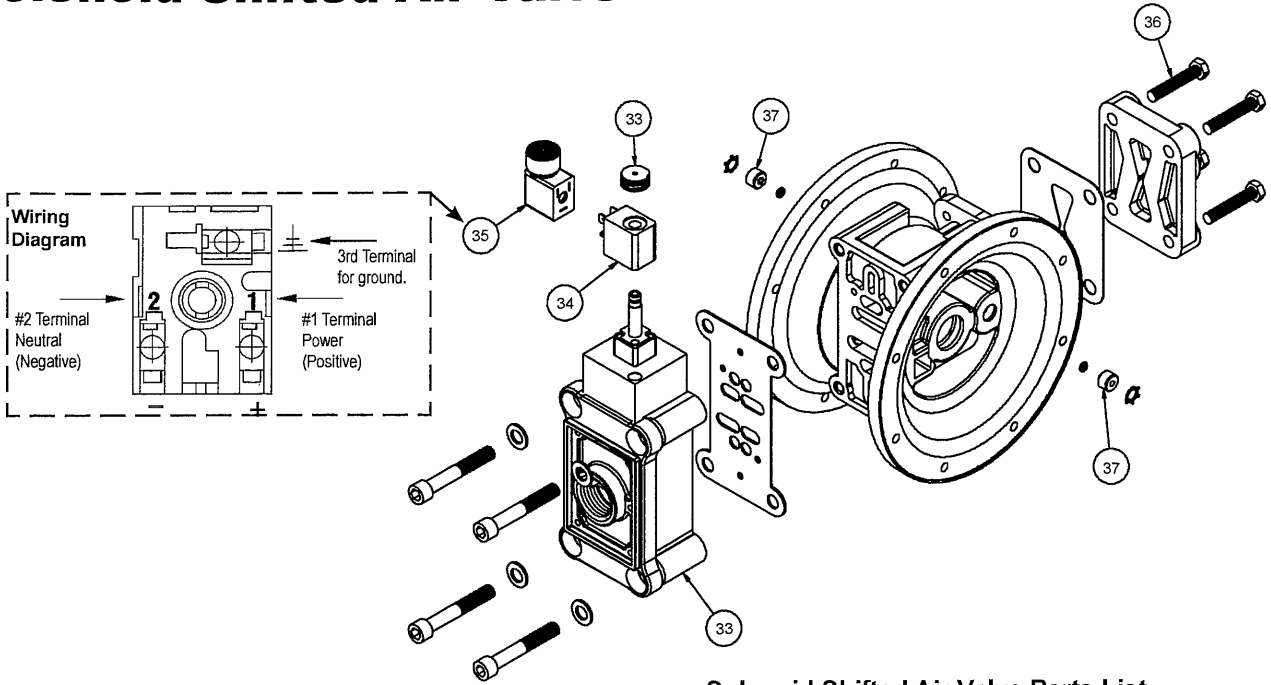

Solenoid Shifted Air Valve Parts List

(Includes all items used on Composite Repair Parts List except as shown)

Item	Part Number	Description	Qty
33	893-097-000	Solenoid Valve, NEMA4	1
34	219-001-000	Solenoid Coil, 24VDC	1
	219-004-000	Solenoid Coil, 24VAC/12VDC	1
	219-002-000	Solenoid Coil, 120VAC	1
	219-003-000	Solenoid Coil, 240VAC	1
35	241-001-000	Connector, conduit	1
	241-003-000	Conduit Connector with Suppression Diode (DC Only)	1
36	170-045-330	Capscrew, Hex HD 5/16-18 x 1.25	4
37	618-050-150	Plug	2



IEC EEx m T4



For Explosion Proof Solenoid Coils used in North America and outside the European Union.

34	219-009-001	Solenoid Coil, 120VAC 60 Hz	1
	219-009-002	Solenoid Coil, 240VAC 60 Hz	1
	219-009-003	Solenoid Coil, 12VDC	1
	219-009-004	Solenoid Coil, 24VDC	1
	219-009-005	Solenoid Coil, 110VAC 50 Hz	1
	219-009-006	Solenoid Coil, 230VAC 50 Hz	1

Note: Item 35 (Conduit Connector) is not required



II 2G EEx m c II T5
II 3/2 G Ex m c II T5
II 2D c IP65 T100°C

* For ATEX Compliant Solenoid Coils used in the European Union

34	219-011-001	Solenoid Coil, Single mounting 12 VDC, 3.3W / 267mA	1
	219-011-002	Solenoid Coil, Single mounting 24 VDC, 3.3W / 136mA	1
	219-011-003	Solenoid Coil, Single mounting 110/120 VAC, 3.4W / 29mA	1
	219-011-004	Solenoid Coil, Single mounting 220/240 VAC, 3.4W / 15mA	1

Note: Item 35 (Conduit Connector) is not required

Compressed Air Temperature Range: Maximum Ambient Temperature to plus 50°C

WWW.SANDPIPERPUMP.COM

SANDPIPER
A WARREN RUPP, INC. BRAND

s1fmdl1sm-rev1011

Solenoid Shifted Air Distribution Valve Option

Warren Rupp's solenoid shifted, air distribution valve option utilizes electrical signals to precisely control your SANDPIPERs speed. The solenoid coil is connected to a customer - supplied control. Compressed air provides the pumping power, while electrical signals control pump speed (pumping rate).

Operation

The Solenoid Shifted SANDPIPER has a solenoid operated, air distribution valve in place of the standard SANDPIPERs pilot operated, air distribution valve. Where a pilot valve is normally utilized to cycle the pump's air distribution valve, an electric solenoid is utilized. As the solenoid is powered, one of the pump's air chambers is pressurized while the other chamber is exhausted. When electric power is turned off, the solenoid shifts and the pressurized chamber is exhausted while the other chamber is pressurized. By alternately applying and removing power to the solenoid, the pump cycles much like a standard SANDPIPER pump, with one exception. This option provides a way to precisely control and monitor pump speed.

Before Installation

Before wiring the solenoid, make certain it is compatible with your system voltage.

*Special Conditions For Safe Use

A fuse corresponding to its rated current (max. $3 \cdot I_{rat}$ according IEC 60127-2-1) or a motor protecting switch with short-circuit and thermal instantaneous tripping (set to rated current) shall be connected in series to each solenoid as short circuit protection. For very low rated currents of the solenoid the fuse of lowest current value according to the indicated IEC standard will be sufficient. The fuse may be accommodated in the associated supply unit or shall be separately arranged. The rated voltage to the fuse shall be equal to or greater than the stated rated voltage of the magnet coil. The breakage capacity of the fuse-link shall be as high as or higher than the maximum expected short circuit current at the location of the installation (usually 1500 A). A maximum permissible ripple of 20% is valid for all magnets of direct-current design.

SUPPLEMENT SHEET FOR
SERVICE MANUAL s1fmdl1sm-REV1011

PUMP MODEL/TYPE S1FB1ABWANS000*

UNIT SUPPLIED WITH PARTS

ITEM	PART NUMBER	DESCRIPTION	QTY
2	050.028.600	CHECK BALL	4.00
2	560.091.611	O-RING	8.00
29	722.098.110	SEAT, BALL CHECK	4.00

PARTS BEING REPLACED

ITEM	PART NUMBER	DESCRIPTION	QTY
2	050.028.360	CHECK BALL	4.00
29	722.098.550	SEAT, CHECK BALL	4.00

**WARREN
RUPP**

IDEX
IDEX CORPORATION